

EN

OPERATING MANUAL
LASER DISTANCE MEASURING
DEVICE



Table of contents

Notes regarding the operating manual.....	1
Safety	2
Information about the device.....	3
Technical data	4
Transport and storage.....	5
Operation	5
Fault indications	10
Maintenance and repair	11
Disposal	11

Notes regarding the operating manual

Symbols

**Warning of laser radiation**

This symbol indicates dangers to the health of persons due to laser radiation.

**Warning**

This signal word indicates a hazard with an average risk level which, if not avoided, can result in serious injury or death.

**Caution**

This signal word indicates a hazard with a low risk level which, if not avoided, can result in minor or moderate injury.

Note

This signal word indicates important information (e.g. material damage), but does not indicate hazards.

**Info**

Information marked with this symbol helps you to carry out your tasks quickly and safely.

**Follow the manual**

Information marked with this symbol indicates that the operating manual must be observed.

You can download the current version of the operating manual and the EU declaration of conformity via the following link:



BD 21

<http://hub.trotec.com/?id=40260>

BD 26

<http://hub.trotec.com/?id=40261>

Safety

Read this manual carefully before starting or using the device. Always store the manual in the immediate vicinity of the device or its site of use!



Warning

Read all safety warnings and all instructions.

Failure to follow the warnings and instructions may result in electric shock, fire and / or serious injury.

Save all warnings and instructions for future reference.

This appliance can be used by children aged from 8 years and above and persons with reduced physical, sensory or mental capabilities or lack of experience and knowledge if they have been given supervision or instruction concerning use of the appliance in a safe way and understand the hazards involved.

Children shall not play with the appliance. Cleaning and user maintenance shall not be made by children without supervision.

- Do not use the device in potentially explosive rooms.
- Do not use the device in aggressive atmosphere.
- Do not immerse the device in water. Do not allow liquids to penetrate into the device.
- The device may only be used in dry surroundings and must not be used in the rain or at a relative humidity exceeding the operating conditions.
- Protect the device from permanent direct sunlight.
- Do not remove any safety signs, stickers or labels from the device. Keep all safety signs, stickers and labels in legible condition.
- Do not open the device with a tool.
- Avoid looking directly into the laser beam.
- Never point the laser beam at people or animals.
- Only use the device if sufficient safety precautions were taken at the surveyed location (e.g. when performing measurements along public roads, on building sites etc.). Otherwise do not use the device.
- Observe the storage and operating conditions as given in the Technical data chapter.

Intended use

Only use the laser distance measuring device BD21 / BD26 for measuring distances, areas and volumes by means of the integrated laser and within the measuring range specified in the technical data. Observe and comply with the technical data.

To use the device for its intended use, only use accessories and spare parts which have been approved by Trotec.

Improper use

Do not use the laser distance measuring device BD21 / BD26 in potentially explosive atmospheres or for measurements in liquids. Never point it at people or animals. Trotec accepts no liability for damages resulting from improper use. In such a case, any warranty claims will be voided.

Any unauthorised modifications, alterations or structural changes to the device are forbidden.

Personnel qualifications

People who use this device must:

- be aware of the dangers that occur when working with laser measuring devices.
- have read and understood the operating manual, especially the Safety chapter.

Residual risks



Warning of laser radiation

Laser class 2, P max.: < 1 mW, λ: 650 nm, EN 60825-1:2014

Do not look directly into the laser beam or the opening from which it emerges.

Never point the laser beam at people, animals or reflective surfaces. Even brief eye contact can lead to eye damage.

Examining the laser output aperture by use of optical instruments (e.g. magnifying glass, magnifiers and the like) entails the risk of eye damage.

When working with a laser of class 2, observe the national regulations on wearing eye protection.



Warning

Risk of suffocation!

Do not leave the packaging lying around. Children may use it as a dangerous toy.



Warning

The device is not a toy and does not belong in the hands of children.



Warning

Dangers can occur at the device when it is used by untrained people in an unprofessional or improper way! Observe the personnel qualifications!



Caution

Keep a sufficient distance from heat sources.

Note

To prevent damages to the device, do not expose it to extreme temperatures, extreme humidity or moisture.

Note

Do not use abrasive cleaners or solvents to clean the device.

Information about the device

Device description

The laser distance measuring device is used to determine distances, areas and volumes in interior spaces. Indirect measurements are carried out employing the Pythagoras function.

The device is equipped with separate operating elements (4) for the different measuring functions. The multi-line and optionally also illuminated display (5) indicates the determined values. Owing to the dust- and splash-proof housing (IP54), the device is also suited for use on construction sites.

Measuring distance

The range of the device can be gathered from the Technical data chapter. Under certain conditions – e.g. at night, in twilight or when the target is hidden in the shade – greater distances are possible even without target plate. During the day use a target plate to increase the distance for poorly reflecting targets.

Target surfaces

There might be measurement errors when the laser encounters colourless liquids (e.g. water), dust-free glass, styrofoam or other semi-permeable materials. The measurement result may also be falsified if the laser encounters a high-gloss surface and is deflected by it. Non-glossy, non-reflective or dark surfaces can extend the measurement duration.

Device depiction

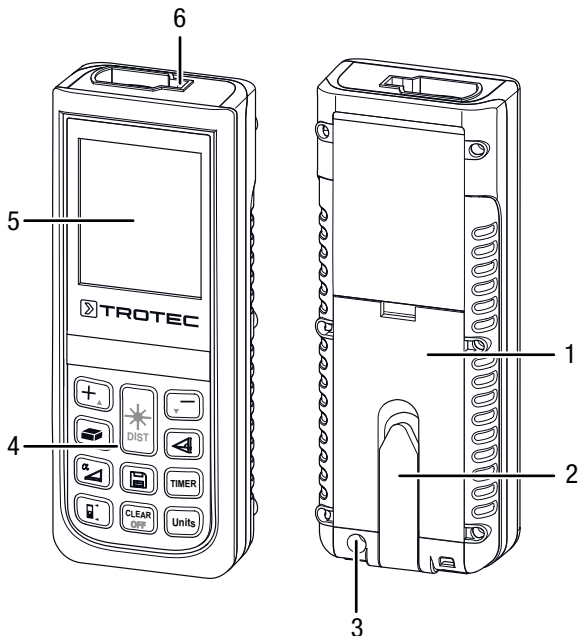

No.	Designation
1	Battery compartment opening
2	Multifunctional end piece
3	Tripod thread
4	Operating elements
5	Display
6	Laser

Operating elements

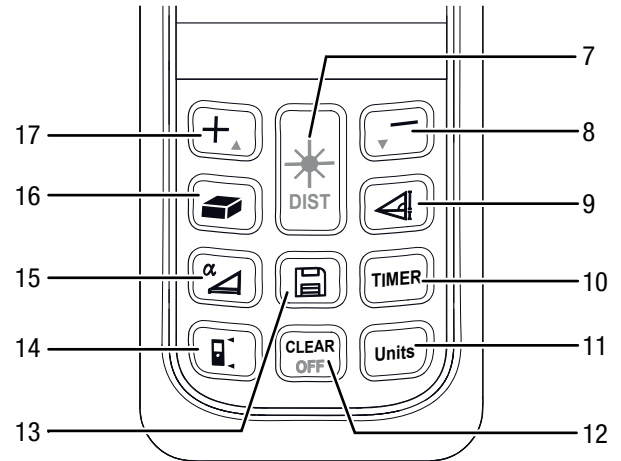

No.	Operating element	
7	Press briefly:	Switch-on/measurement button
	Press for a long time:	Button for permanent distance measurements
8	Press briefly:	Minus button
	Press for a long time:	Signal tone button (on/off)
9	Press briefly:	Button for indirect measurements
10	Press briefly:	Timer button
	Press for a long time:	Setting the timer
11	Press briefly:	Unit button (ft, in, m)
12	Press briefly:	Delete button
	Press for a long time:	Switch-off button
13	Press briefly:	Save button (history)
14	Press briefly:	Reference button
15	Press for a long time:	Inclination button (on/off)
16	Press briefly:	Area/room volume button
17	Press briefly:	Plus button

Display

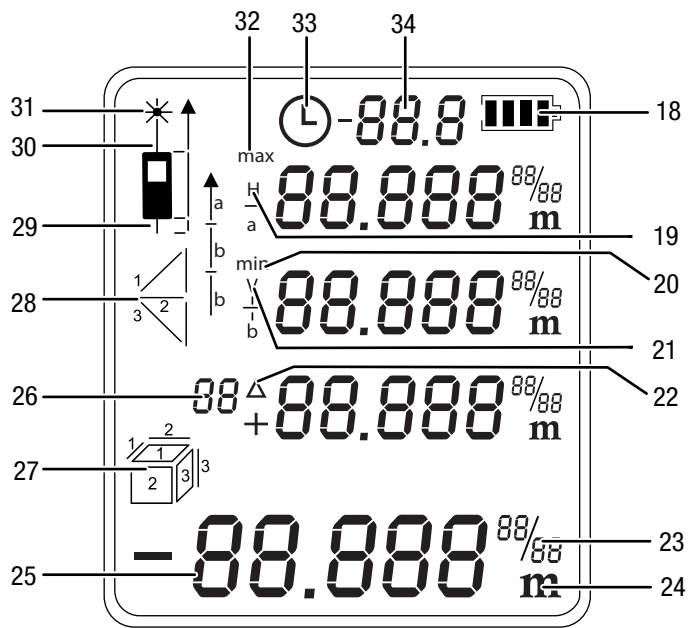

No.	Display element
18	Battery status
19	Horizontal measuring distance
20	Measured minimum value
21	Vertical measuring distance
22	Delta = maximum minus minimum
23	Complementary display when using imperial units
24	Display of the selected unit. Possible units are: ft ³ , ft ² , in, m, m ³ , m ²
25	Measurement value display: The lower measurement value display indicates the last measured value or the result of a calculation. The three upper measurement value displays contain the past three measured values, the minimum and maximum value or the measured values to be added or subtracted.
26	History and timer indication
27	Area measurement Volume measurement
28	Indirect measurement (two auxiliary measurements) Indirect measurement (three auxiliary measurements)
29	Reference value rear
30	Reference value front
31	Laser active
32	Measured maximum value

No.	Display element
33	Timer indication
34	Inclination angle indication

Technical data

Parameter	Value
Model:	BD21 / BD26
Weight:	150 g
Dimensions (H x W x D):	118 x 49 x 27 mm
Measuring range:	BD21: 0.05 to 70 m BD26: 0.05 to 120 m
Accuracy:	±2 mm*
Measuring range resolution:	1 mm
Horizontal measuring range:	±90°
Horizontal measuring range accuracy:	±0.3°
Number of recordings logged in the history:	10
Type of protection:	IP54
Operating temperature:	0 °C to 40 °C
Storage temperature:	-20 °C to 70 °C
Laser output:	< 1 mW (620-690 nm)
Laser class:	II
∅ — l m	6 mm / 30 mm / 60 mm l 10 m / 50 m / 100 m
Power supply:	2 x Alkaline LR6 AAA batteries, 1.5 V or NiMH 1.2 V to 1.5 V (rechargeable batteries) Battery life approx. 5000 to 8000 measurements
Automatic switch-off of the device:	After approx. 3 minutes of non-use
Automatic switch-off of the laser:	After approx. 30 seconds of non-use
*under favourable conditions (good target surface, room temperature) up to 10 m	

Scope of delivery

- 1 x Laser distance measuring device
- 2 x Alkaline LR6 AAA, 1.5 V battery
- 1 x Device bag
- 1 x Wrist strap
- 1 x Quick guide

Transport and storage

Transport

Use the supplied device bag (37) to transport the device.

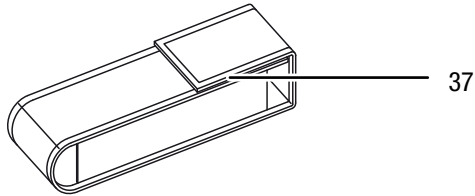

Storage

When the device is not being used, observe the following storage conditions:

- dry,
- protected from dust and direct sunlight,
- with a plastic cover to protect it from invasive dust, if necessary.
- The storage temperature is the same as the range given in the Technical data chapter.
- When storing the device for a long time, remove the batteries.
- Preferably use the supplied device bag to store the device.

Operation

Inserting the batteries

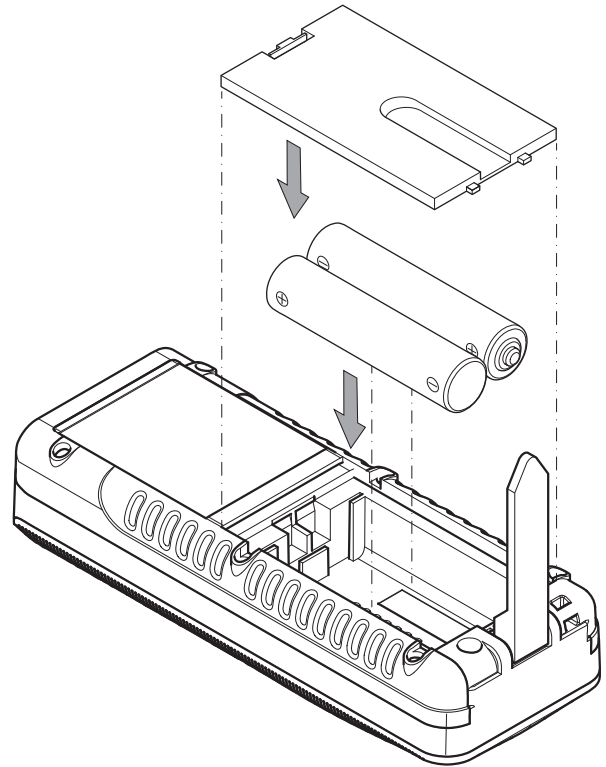

Attaching the wrist strap

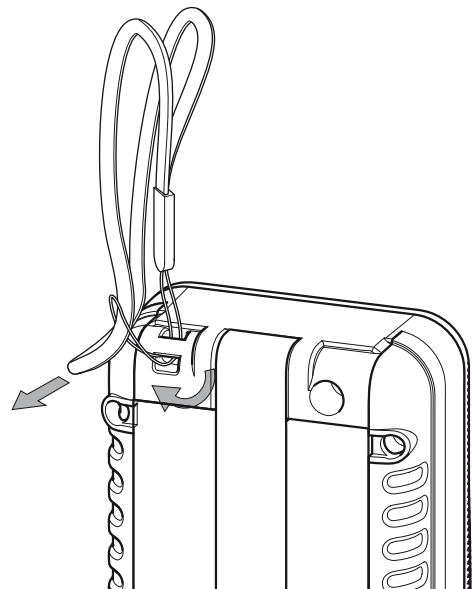

Switch-on

1. Briefly press the Switch-on/measurement button (7).
⇒ The display is switched on and the device is ready for operation.

Switch-off

1. Press the Switch-off button (12) for a long time.
⇒ The display is switched off.

Using the multifunctional end piece

The device is equipped with a multifunctional end piece (2), which you can use e.g. for measurements at corners. It serves for device stabilization.

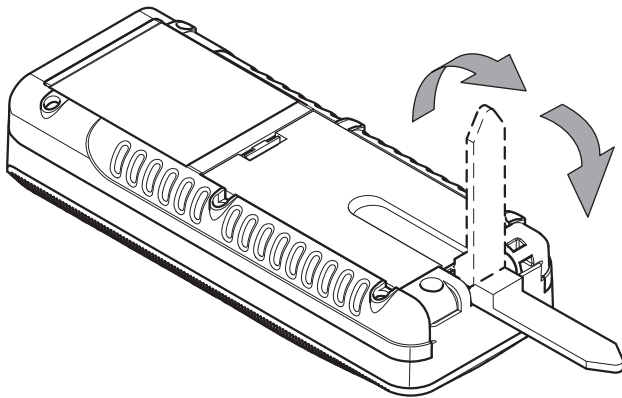

1. Fold out the end piece.
⇒ BD21: The position of the end piece and the associated reference point must be set manually by pressing the button (14).
⇒ BD26: The position of the end piece and the associated reference point are automatically recognized by the device.
⇒ An extended depiction of the reference value rear (29) indication is displayed.

Basic settings

Switching the acoustic signal on/off

1. Press the Minus button (8) for a long time to switch the acoustic signal on or off.
⇒ The switch-on/off process is confirmed by a brief acoustic signal.

Aborting the measurement and deleting the display

1. Briefly press the Delete button (12) to abort the current measurement or to delete the displayed measured values one at a time.

Setting the reference value

The device always measures the total distance starting at the reference point. This means that if the rear end of the device is set as reference point, the length of the device will be part of the measurement. By default the reference point is set to the rear of the device. You can, however, also relocate the reference point to the front part of the device. Proceed as follows:

1. Press the Reference button (14) to relocate the reference point to the front end of the device.
⇒ An acoustic signal is emitted each time the reference point is relocated. Additionally, the indication Reference value front (30) appears.

When switching the device off and then on again, the reference value will automatically be relocated to the rear end of the device.

Changing the units

1. Briefly press the Unit button (11) to switch between the units for the measured values. Available units are **m**, **ft in**, **in** and **ft**.



Info

If no measurement has been performed yet and if you want to switch to another unit, there will be no unit indication at first if you select **ft in**. Only if a measurement is performed or if measured values are already available will the measured values be displayed in the *xx' yy''* format.

Displaying the inclination

1. Briefly press the Inclination button (15).
⇒ The inclination of the device will be indicated in the Inclination display (34).

Calling up a measured value in the device history

The device automatically saves the last 10 measured values. The saved measured values can be called up as follows:

1. Press the Save button (13) to call up the history.
2. Briefly press the Minus button (8) or the Plus button (17) to navigate through the history and call up the saved measured values.
3. You can return to the normal measuring menu by briefly pressing the Delete button (12) or the Measurement button (7).

Setting the timer

The device is provided with an internal timer, which can be used to set a delay after which the measurement begins. The timer can be used for all measuring operations.

- Briefly press the Timer button (10) to activate a delay of 5 seconds.
- Press and hold the Timer button (10) until the desired time is displayed (30 seconds max.).
- Let go of the Timer button (10) to start the timer.
 - The Timer indication (33) and a countdown (26) indicating the remaining seconds will appear on the display.
 - The last five seconds are each accompanied by an acoustic signal.
 - After the expiration of this time the measurement is performed.

Carrying out measurements



Warning of laser radiation

Laser class 2, P max.: < 1 mW, λ: 650 nm, EN 60825-1:2014

Do not look directly into the laser beam or the opening from which it emerges.

Never point the laser beam at people, animals or reflective surfaces. Even brief eye contact can lead to eye damage.

Examining the laser output aperture by use of optical instruments (e.g. magnifying glass, magnifiers and the like) entails the risk of eye damage.

When working with a laser of class 2, observe the national regulations on wearing eye protection.

Carrying out single distance measurement

1. Briefly press the Switch-on/measurement button (7) to activate the laser.
2. Point the laser at the target area.
3. Briefly press the Switch-on/measurement button (7) again to perform a distance measurement.
 - ⇒ The measured value is immediately indicated on the display.

Adding / subtracting measured values

1. Carry out a single distance measurement.
2. Press the Plus button (17) to add the next measured value to the previous one.
Press the Minus button (8) to subtract the next measured value from the previous one.
3. Press the Switch-on/measurement button (7) to determine the next measured value.
 - ⇒ The overall result will be indicated in the lower measurement value display. The individual measured values will be indicated in the upper measurement value displays.

Performing an area measurement

1. Briefly press the Area/room volume button (16) one time.
 - ⇒ The symbol  for area measurement appears on the display.
2. Briefly press the Switch-on/measurement button (7) to carry out the first measurement (e.g. length).
3. Briefly press the Switch-on/measurement button (7) again to carry out the second measurement (e.g. width).
 - ⇒ Upon pressing the Switch-on/measurement button (7) for the second time the device independently calculates the area and displays this value in the lower measurement value display. The most recently measured value will be indicated in one of the upper measurement value displays.

Performing a volume measurement

1. Briefly press the Area/room volume button (16) twice.
 - ⇒ The symbol  for volume measurement appears on the display.
 - ⇒ The side to be measured in each case is indicated on the display by flashing.
2. Briefly press the Switch-on/measurement button (7) to carry out the first measurement (e.g. length).
3. Briefly press the Switch-on/measurement button (7) again to carry out the second measurement (e.g. width).
4. Briefly press the Switch-on/measurement button (7) again to carry out the third measurement (e.g. height).
 - ⇒ Upon pressing the Switch-on/measurement button (7) for the third time the device independently calculates the volume and displays this value in the lower measurement value display.

Performing a non-stop / min and max measurement

Use the non-stop measuring function to correlate measurements e.g. with construction drawings. With this measurement method the device can be moved closer toward the target with the measured value being recalculated roughly every 0.5 seconds. The corresponding maximum and minimum measured values are displayed in the first and second line respectively.

For instance, you can direct the laser beam at a wall and then retreat from it step by step. Keep reading the measured values until the desired distance is achieved.

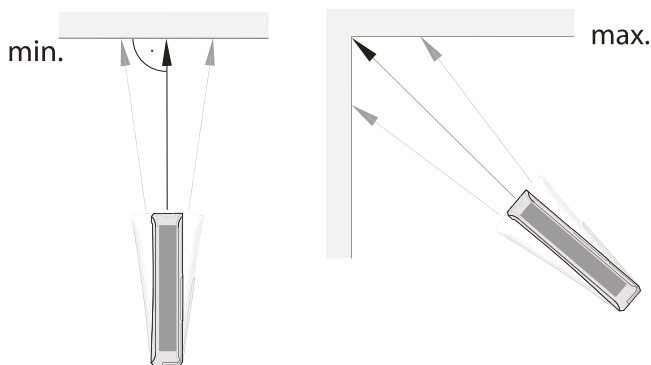

Indirect height measurement (Pythagoras)

Using this method the length of an unknown straight-line segment can be determined via the Pythagorean Theorem. This method is suitable for e.g. height measurements.

The measurement result is calculated by determining the distance A and the inclination angle (standard setting) or by determining the distances A and B.

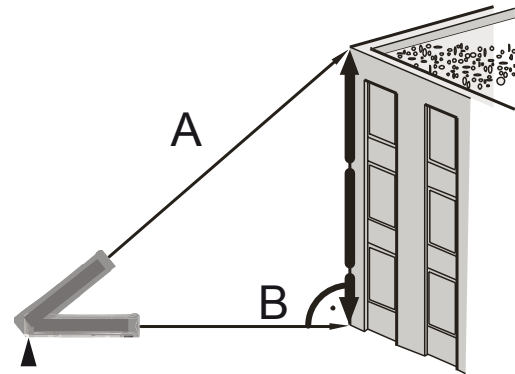

Measurement with distance A and inclination angle:

1. Briefly press the Button for indirect measurements (9) one time.

- ⇒ The symbol for indirect measurements appears on the display.
- ⇒ The inclination angle is displayed in the third line of the upper measurement value display on the right-hand side (see example 33.0°).
- ⇒ The bar with number 1 (hypotenuse) flashes.

1. Press the Switch-on/measurement button (7) for a long time until an acoustic signal can be heard.
 2. With reference to the target point, move the device slowly back and forth as well as up and down (e.g. in a corner).
 3. Briefly press the Switch-on/measurement button (7) to terminate the non-stop measurement.
- ⇒ The maximum and minimum measured values and the difference (Δ) between these two are indicated on the display. Additionally, the last measured value will be displayed in the bottommost line.

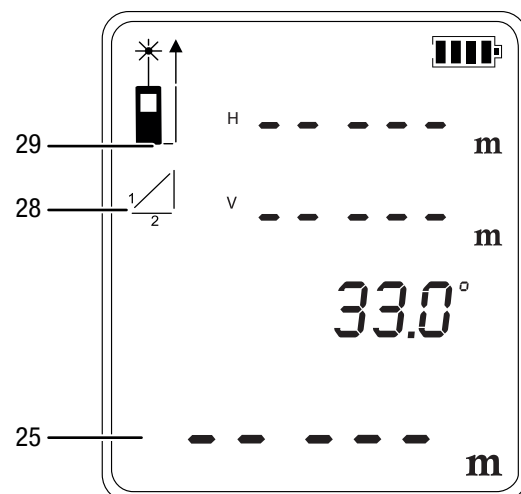

2. Aim the device at the highest point (A) and briefly press the Switch-on/measurement button (7) once to perform a measurement. Make sure to hold the device as steady as possible and place it level on the ground with the two rear edges. **The position at the two rear edges must not be changed during the measurements!**

- ⇒ Both measurement and calculation are effected.
- ⇒ The horizontal (1st line) and vertical (2nd line) distance values are indicated in the upper measurement value display.
- ⇒ The line segment to be determined is displayed as result in the lower measurement value display (25).

Measurement with distances A and B:

1. Briefly press the Button for indirect measurements (9) one time.
 - ⇒ The symbol  for indirect measurements appears on the display.
 - ⇒ The bar with number 1 (hypotenuse) flashes.
2. Press the Inclination button (15) **for a long time**.
 - ⇒ There will be no angle displayed.

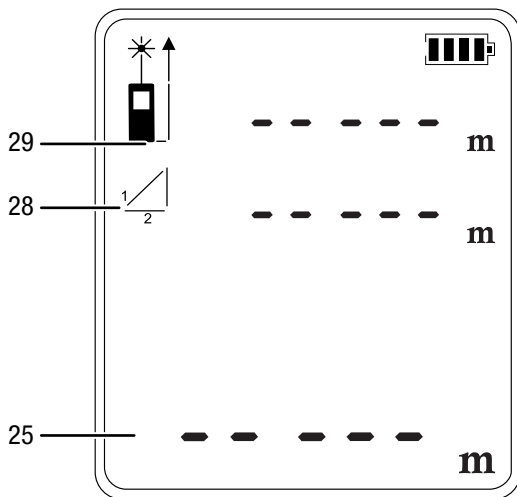

3. First, aim the device at the highest point (A) and briefly press the Switch-on/measurement button (7) once to perform a measurement. Make sure to hold the device as steady as possible and place it level on the ground with the two rear edges. **The position at the two rear edges must not be changed during the measurements!**

- ⇒ The length of the line segment will be indicated in the 1st line of the upper measurement value display.
4. Align the device horizontally (point B) and briefly press the Switch-on/measurement button (7) one time to measure the horizontal distance.
 - ⇒ The second measured value will be indicated in the second line of the upper measurement value display.
 - ⇒ The line segment to be determined is displayed as result in the lower measurement value display (25).

Twofold indirect height measurement

This method is suitable for e.g. height measurements.

The measurement result is calculated by determining the distances A and C as well as the inclination angle (standard setting) or by determining the distances A, B and C.

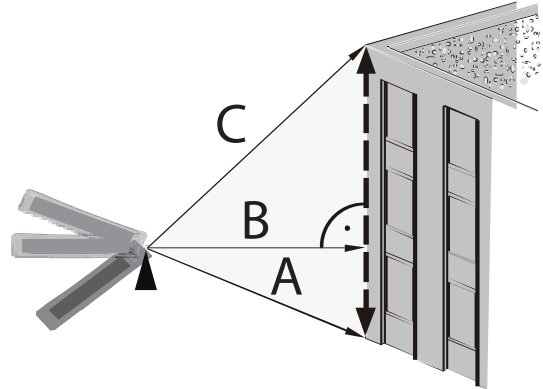

Measurement with distances A, C and inclination angle:

1. Briefly press the Button for indirect measurements (9) twice.

- ⇒ The symbol  for indirect measurements appears on the display.
- ⇒ The inclination angle is displayed in the second line of the upper measurement value display on the right-hand side (see example 31.1°).
- ⇒ The bar with number 1 (hypotenuse) flashes.

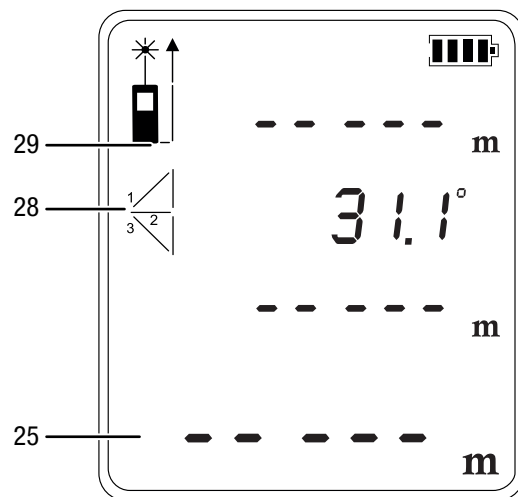

2. First, aim the device at the highest point (C) and briefly press the Switch-on/measurement button (7) once to perform a measurement. In doing so, hold the device as steady as possible. **The alignment of the device in relation to the reference point must not be changed during the measurements!**

- ⇒ The first measured value will be displayed in the upper measurement value display.

3. Aim the device at the lowest point (A) and briefly press the Switch-on/measurement button (7) once to perform a measurement.
 - ⇒ The second measured value will be indicated in the third line of the upper measurement value display.
 - ⇒ The angle will be indicated in the second line of the upper measurement value display.
 - ⇒ The line segment to be determined is displayed as result in the lower measurement value display (25).

Measurement with distances A, B and C:

1. Briefly press the Button for indirect measurements (9) twice.
 - ⇒ The symbol  for indirect measurements appears on the display.
2. Press the Inclination button (15) **for a long time**.
 - ⇒ There will be no angle displayed.

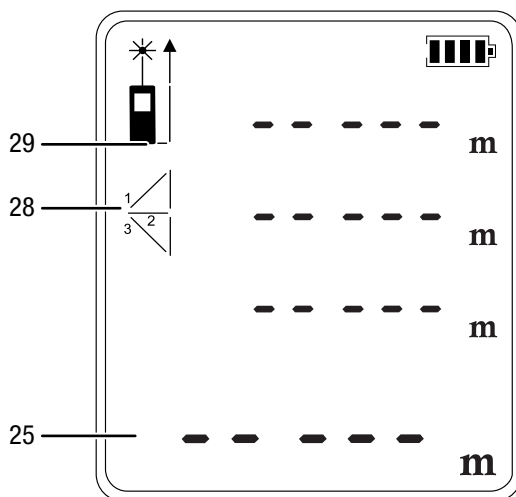

3. First, aim the device at the highest point (C) and briefly press the Switch-on/measurement button (7) once to perform a measurement. In doing so, hold the device as steady as possible. **The alignment of the device in relation to the reference point must not be changed during the measurements!**
 - ⇒ The first measured value will be displayed in the upper measurement value display.
4. Align the device horizontally (point B) and briefly press the Switch-on/measurement button (7) one time to measure the horizontal distance.
 - ⇒ The second measured value will be indicated in the second line of the upper measurement value display.
5. Aim the device at the lowest point (A) and briefly press the Switch-on/measurement button (7) once to perform a measurement.
 - ⇒ The third measured value will be indicated in the third line of the upper measurement value display.
 - ⇒ The line segment to be determined is displayed as result in the lower measurement value display (25).

Fault indications

The following fault indications can appear in the lower measurement value display together with the word *INFO*:

Display	Cause	Remedy
101	The reception of the reflected signal is too weak.	Repeat measurement on another surface with better reflective properties or use a target plate.
102	The reception of the reflected signal is too strong.	
201	The ambient light is too intense.	Change the ambient light conditions for the measurement.
203	The batteries are almost empty.	Change the batteries, see chapter Battery change.
301	The temperature is too high.	Allow the device to cool down. Observe the permissible operating temperature according to the Technical data chapter.
302	The temperature is too low.	Allow the device to warm up. Observe the permissible operating temperature according to the Technical data chapter.
401	Hardware fault	Repeatedly switch the device on and off. If the symbol does not disappear, please contact your retailer.
402	Calculation error	Repeat the measurement. Pay attention to the measurement sequence and position of the device.

Maintenance and repair

Cleaning

Clean the device with a soft, damp and lint-free cloth. Ensure that no moisture enters the housing. Do not use any sprays, solvents, alcohol-based cleaning agents or abrasive cleaners, but only clean water to moisten the cloth.

Repair

Do not modify the device or install any spare parts. For repairs or device testing, contact the manufacturer.

Battery change

Note

Make sure that the surface of the device is dry and the device is switched off.

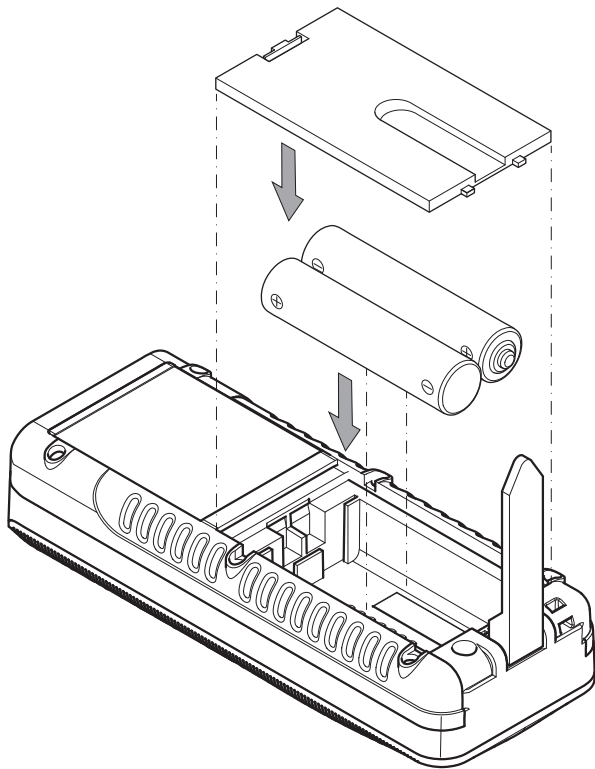

Disposal



The icon with the crossed-out waste bin on waste electrical or electronic equipment stipulates that this equipment must not be disposed of with the household waste at the end of its life. You will find collection points for free return of waste electrical and electronic equipment in your vicinity. The addresses can be obtained from your municipality or local administration. For further return options provided by us please refer to our website www.trotec24.com.

The separate collection of waste electrical and electronic equipment aims to enable the re-use, recycling and other forms of recovery of waste equipment as well as to prevent negative effects for the environment and human health caused by the disposal of hazardous substances potentially contained in the equipment.

You are responsible for deleting any personal data stored on the waste equipment to be disposed of.

In the European Union, batteries and accumulators must not be treated as domestic waste, but must be disposed of professionally in accordance with Directive 2006/66/EC of the European Parliament and of the Council of 6 September 2006 on batteries and accumulators. Please dispose of batteries and accumulators according to the relevant legal requirements.

Trotec GmbH & Co. KG

Grebener Str. 7
D-52525 Heinsberg

☎ +49 2452 962-400

☎ +49 2452 962-200

info@trotec.com

www.trotec.com